

**[ 1 ] PLAN**  
1/4"=1'-0"

**PURCHASE COLLEGE**  
STATE UNIVERSITY OF NEW YORK  
735 ANDERSON HILL RD  
PURCHASE, NY 10577-1400

ARCHITECT  
**dimovskiarhitecture**  
59 Kensico Road, Thornwood, NY 10594  
(914) 747-3500 | (914) 747-3588 fax  
www.dimovskiarhitecture.com

MEP ENGINEER  
**Collado ENGINEERING**  
2 HOLLAND AVENUE  
WHITE PLAINS NY 10603  
(914) 332-7658

STRUCTURAL ENGINEER  
**SZEWCAZ ASSOCIATES**  
CONSULTING ENGINEERS  
AVON PARK NORTH  
200 FERRIS DRIVE  
AVON, CT 06001  
TEL: 860.677.6379  
800.622.8888

STAGE CONSULTANT  
**stages**  
300 Raritan Ave, 2nd Flr Highland Park, NJ 08904 732.333.8003  
stagesconsultants.com

NO.	REVISION/ISSUE	DATE
2.	ISSUE FOR BID	06/18/2018
1.	ISSUE FOR BUDGETING	06/04/2018

SEAL

PROJECT  
**INTERIOR RENOVATION MUSIC SOUND STAGE**

DATE:	06/18/2018
PROJECT NO.:	DA 1845 / SU-062518
DRAWN BY:	SEM
CHECKED BY:	AS
SCALE:	AS NOTED

DRAWING TITLE  
**THEATRE RIGGING PLAN**

SHEET NO.  
TR1.10

FOR COORDINATION ONLY.  
PROCURED UNDER  
SEPARATE CONTRACT.

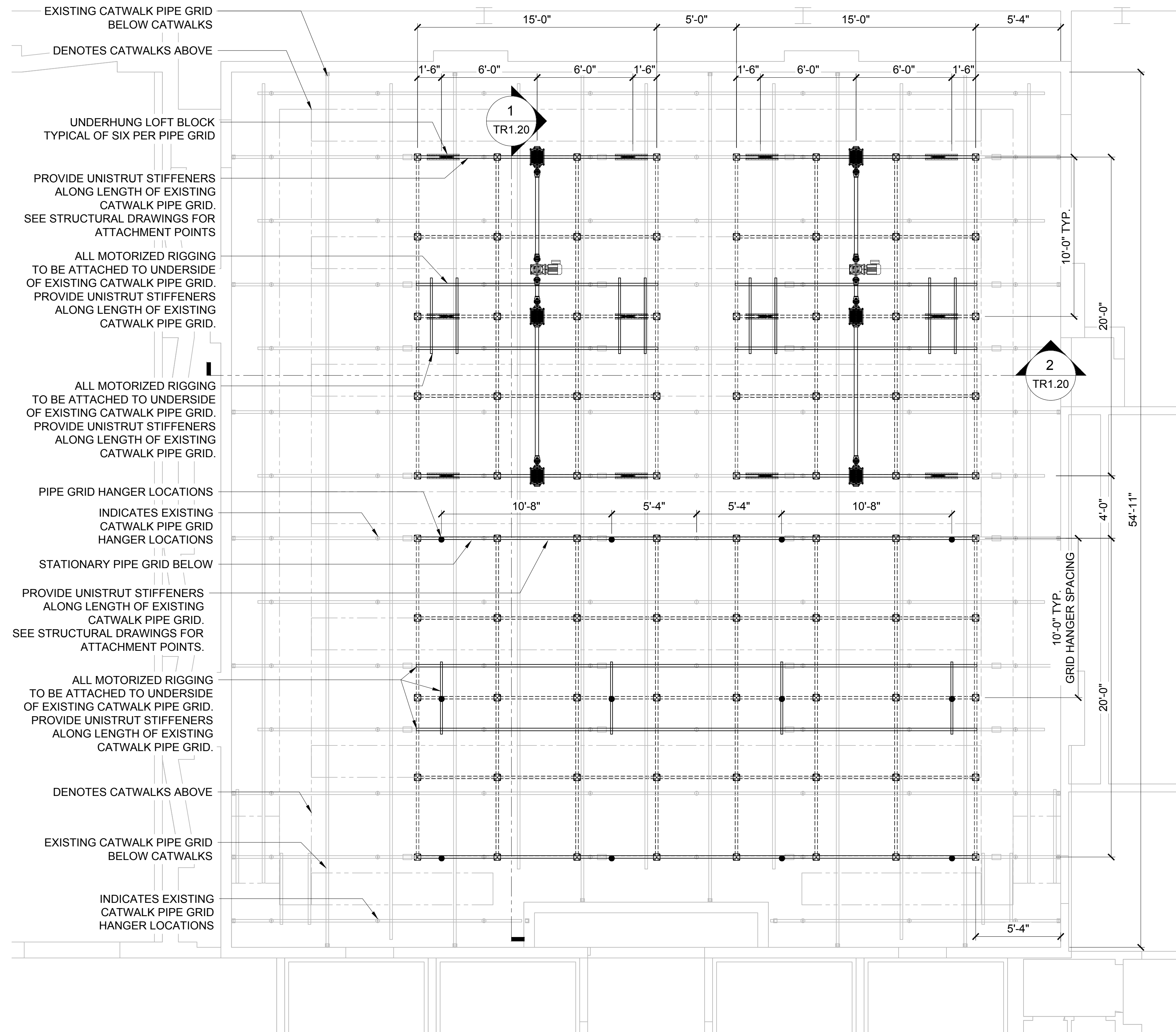

**1** PLAN - MOTORIZED RIGGING AND GRID HANGERS  
1/4"=1'-0"

**PURCHASE COLLEGE**  
STATE UNIVERSITY OF NEW YORK  
735 ANDERSON HILL RD  
PURCHASE, NY 10577-1400

ARCHITECT  
**dimovskiarchitecture**  
59 Kensico Road, Thornwood, NY 10594  
(914) 747-3500 | (914) 747-3588 fax  
www.dimovskiarchitecture.com

MEP ENGINEER  
**Collado ENGINEERING**  
2 HOLLAND AVENUE  
WHITE PLAINS NY 10603  
(914) 332-7658

STRUCTURAL ENGINEER  
**SZEWICZAK ASSOCIATES**  
CONSULTING ENGINEERS  
AVON PARK NORTH  
200 FERRIS DRIVE  
AVON, CT 06001  
TEL: 860.677.6370  
800.622.8888

STAGE CONSULTANT  
**stages**  
300 Raritan Ave, 2nd Flr  
Highland Park, NJ 08904  
732.333.8003  
stagesconsultants.com

NO.	REVISION/ISSUE	DATE
2.	ISSUE FOR BID	06/18/2018
1.	ISSUE FOR BUDGETING	06/04/2018

SEAL

PROJECT  
**INTERIOR RENOVATION MUSIC SOUND STAGE**

DATE: 06/18/2018  
PROJECT NO: DA 1845 / SU-062518  
DRAWN BY: SEM  
CHECKED BY: AS  
SCALE: AS NOTED

DRAWING TITLE  
**THEATRE RIGGING PLAN**

SHEET NO.  
**TR1.11**

FOR COORDINATION ONLY.  
PROCURED UNDER  
SEPARATE CONTRACT.

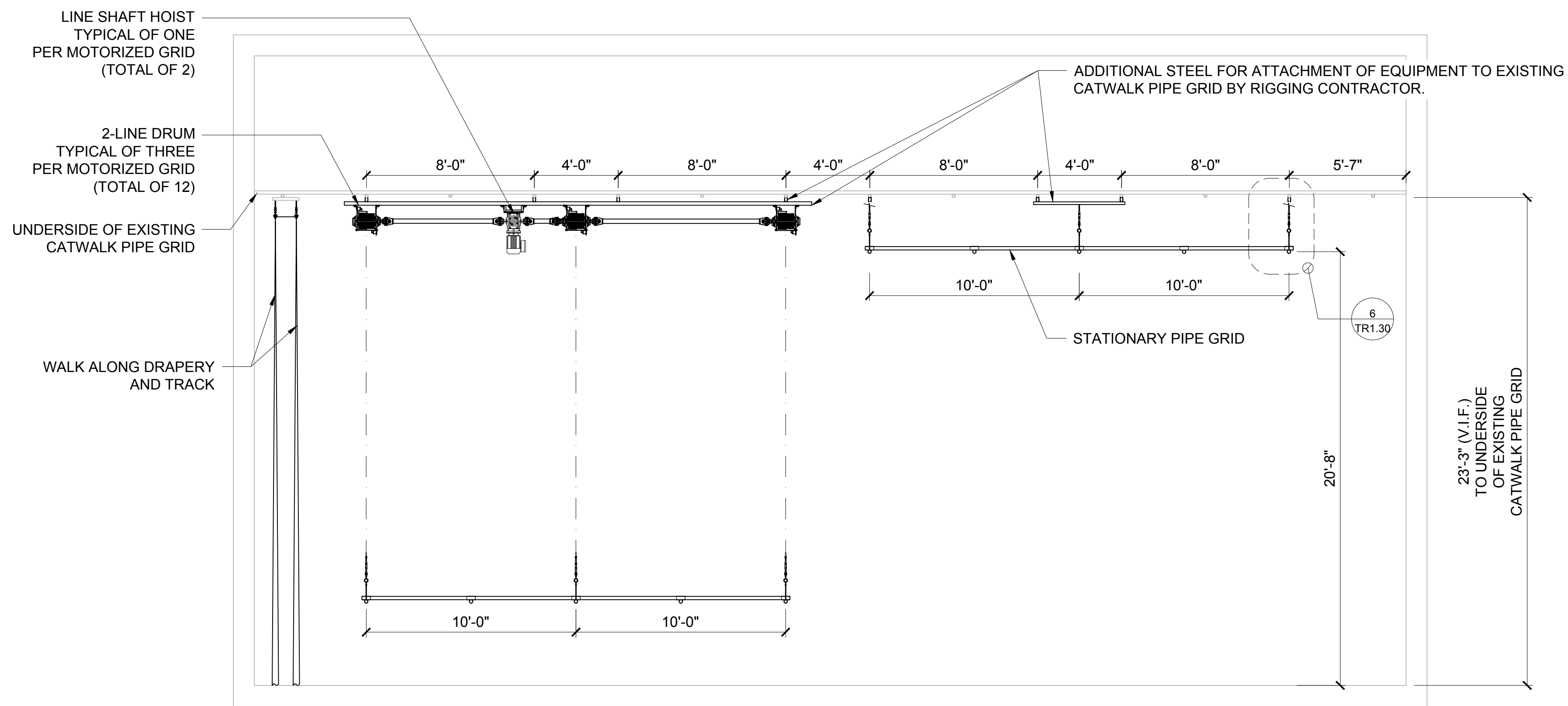

**1** COMPOSITE SECTION- LONGITUDINAL  
1/4"=1'-0"

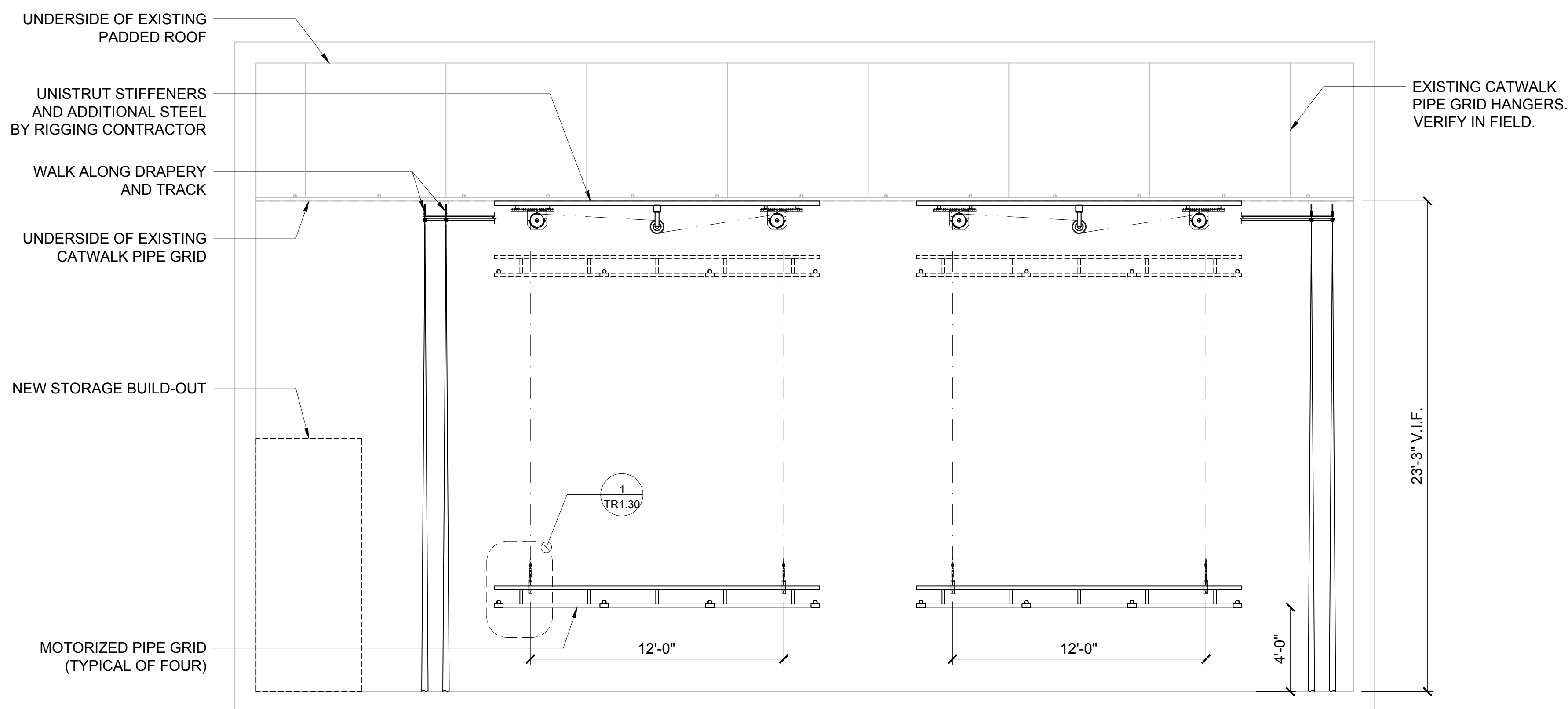

**2** COMPOSITE SECTION - TRANSVERSE  
1/4"=1'-0"

FOR COORDINATION ONLY.  
PROCURED UNDER  
SEPARATE CONTRACT.

**PURCHASE COLLEGE**  
STATE UNIVERSITY OF NEW YORK  
735 ANDERSON HILL RD  
PURCHASE, NY 10577-1400

ARCHITECT  
**dimovskiarchitecture**  
59 Kensico Road, Thornwood, NY 10594  
(914) 747-3500 | (914) 747-3588 fax  
www.dimovskiarchitecture.com

MEP ENGINEER  
**Collado ENGINEERING**  
2 HOLLAND AVENUE  
WHITE PLAINS NY 10603  
(914) 332-7658

STRUCTURAL ENGINEER  
**SZEWCAZ ASSOCIATES**  
CONSULTING ENGINEERS  
AVON PARK NORTH  
200 FERRIS DRIVE  
AVON, CT 06001  
TEL: 860.677.6370  
860.677.6369

STAGE CONSULTANT  
**stages**  
300 Raritan Ave, 2nd Flr Highland Park, NJ 08904  
732.333.8003  
stagesconsultants.com

2.	ISSUE FOR BID	06/18/2018
1.	ISSUE FOR BUDGETING	06/04/2018
NO.	REVISION/ISSUE	DATE

SEAL

PROJECT  
**INTERIOR RENOVATION MUSIC SOUND STAGE**

DATE: 06/18/2018  
PROJECT NO: DA 1845 / SU-062518  
DRAWN BY: SEM  
CHECKED BY: AS  
SCALE: AS NOTED

DRAWING TITLE  
**THEATRE RIGGING COMPOSITE SECTIONS**

SHEET NO.  
**TR1.20**



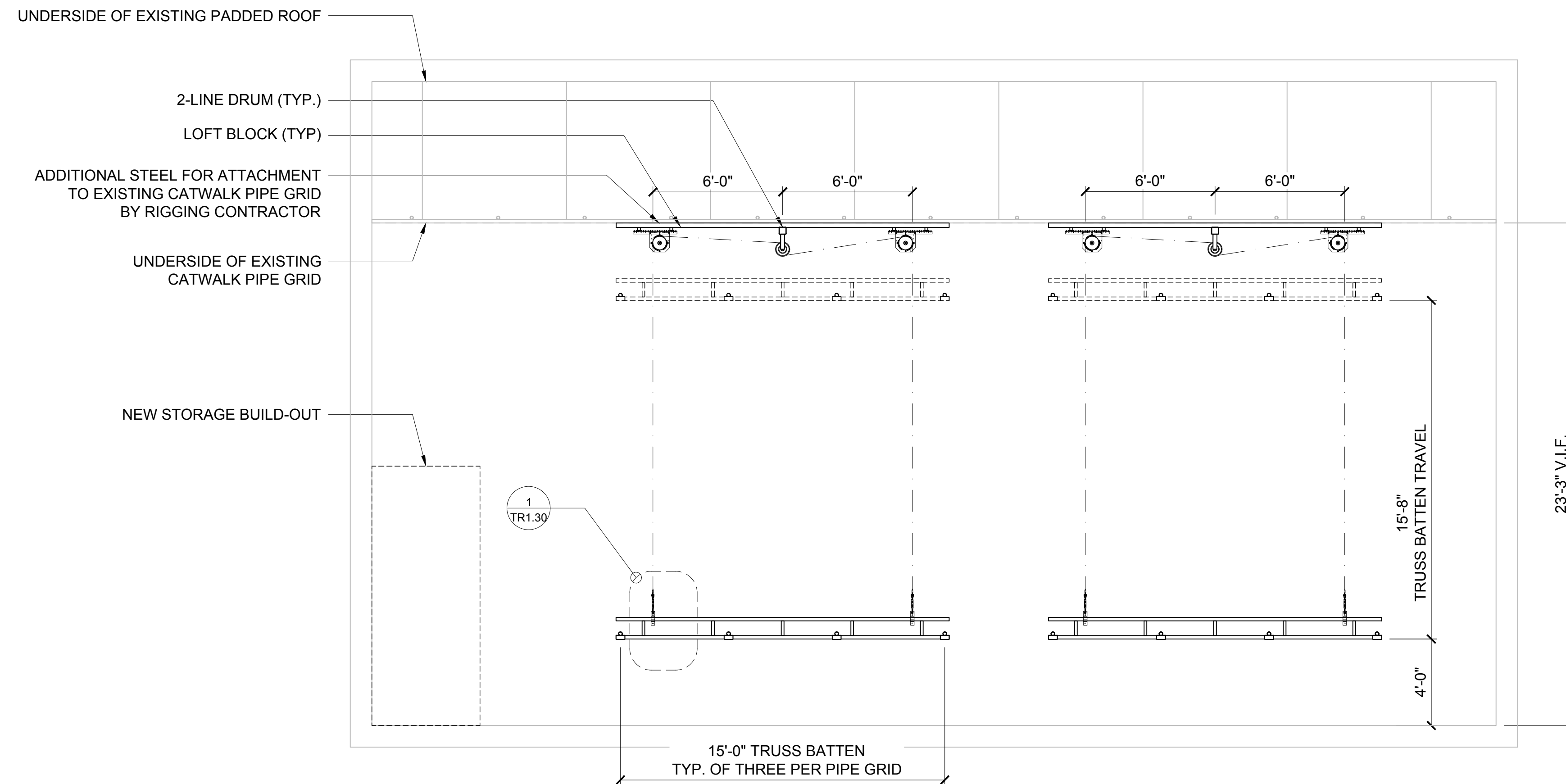

**[ 1 ]** TRANSVERSE SECTION - MOTORIZED PIPE GRID - BASE BID  
1/4"=1'-0"

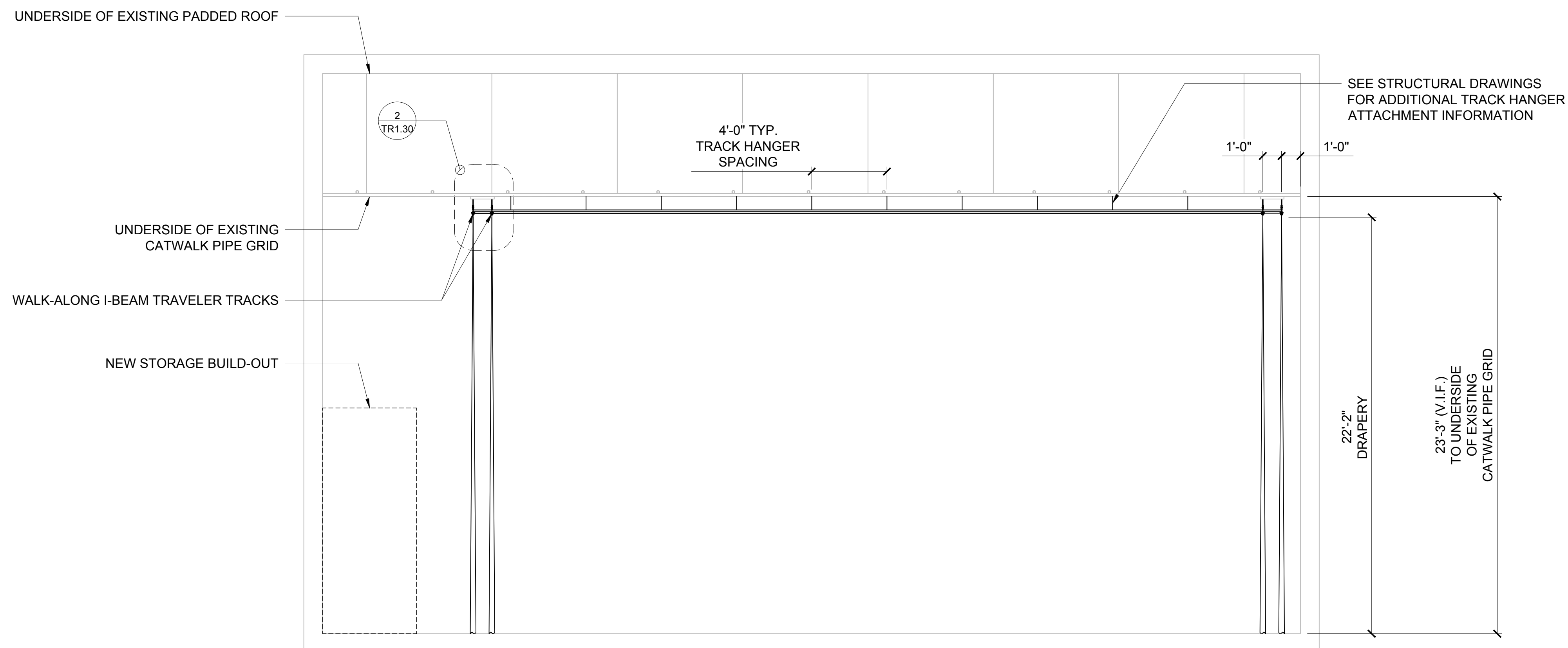

**[ 2 ]** TRANSVERSE SECTION - WALK-ALONG TRAVELER TRACK  
1/4"=1'-0"

FOR COORDINATION ONLY.  
PROCURED UNDER  
SEPARATE CONTRACT.

**PURCHASE COLLEGE**  
STATE UNIVERSITY OF NEW YORK  
735 ANDERSON HILL RD  
PURCHASE, NY 10577-1400

ARCHITECT  
**dimovskiarhitecture**  
59 Kensico Road, Thornwood, NY 10594  
(914) 747-3500 | (914) 747-3588 fax  
www.dimovskiarhitecture.com

MEP ENGINEER  
**Collado ENGINEERING**  
2 HOLLAND AVENUE  
WHITE PLAINS NY 10603  
(914) 332-7658

STRUCTURAL ENGINEER  
**SZEWCAZ ASSOCIATES**  
CONSULTING ENGINEERS  
AVON PARK NORTH  
200 FERRIS DRIVE  
AVON, CT 06001  
TEL: 860.677.4379  
860.677.4380

STAGE CONSULTANT  
**stages**  
300 Raritan Ave, 2nd Flr 732.333.8003  
Highland Park, NJ 08904 stagesconsultants.com

NO.	REVISION/ISSUE	DATE
2.	ISSUE FOR BID	06/18/2018
1.	ISSUE FOR BUDGETING	06/04/2018

SEAL

PROJECT  
**INTERIOR RENOVATION MUSIC SOUND STAGE**

DATE: 06/18/2018  
PROJECT NO: DA 1845 / SU-062518  
DRAWN BY: SEM  
CHECKED BY: AS  
SCALE: AS NOTED

DRAWING TITLE  
**THEATRE RIGGING SECTIONS**

SHEET NO.  
TR1.21

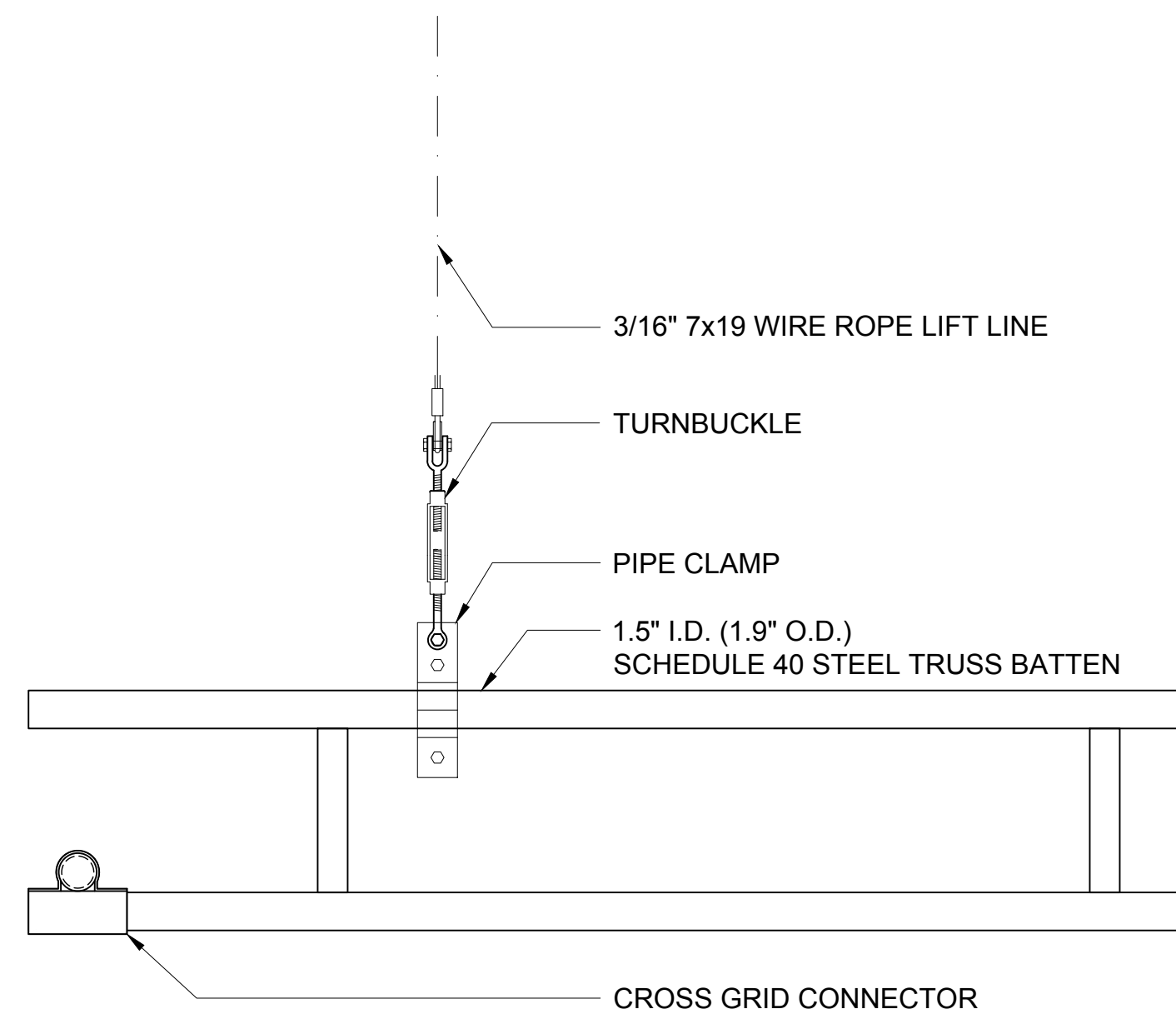

**[ 1 ]** **MOTORIZED PIPE GRID TRUSS BATTEN TERMINATION**  
1 1/2"=1'-0"

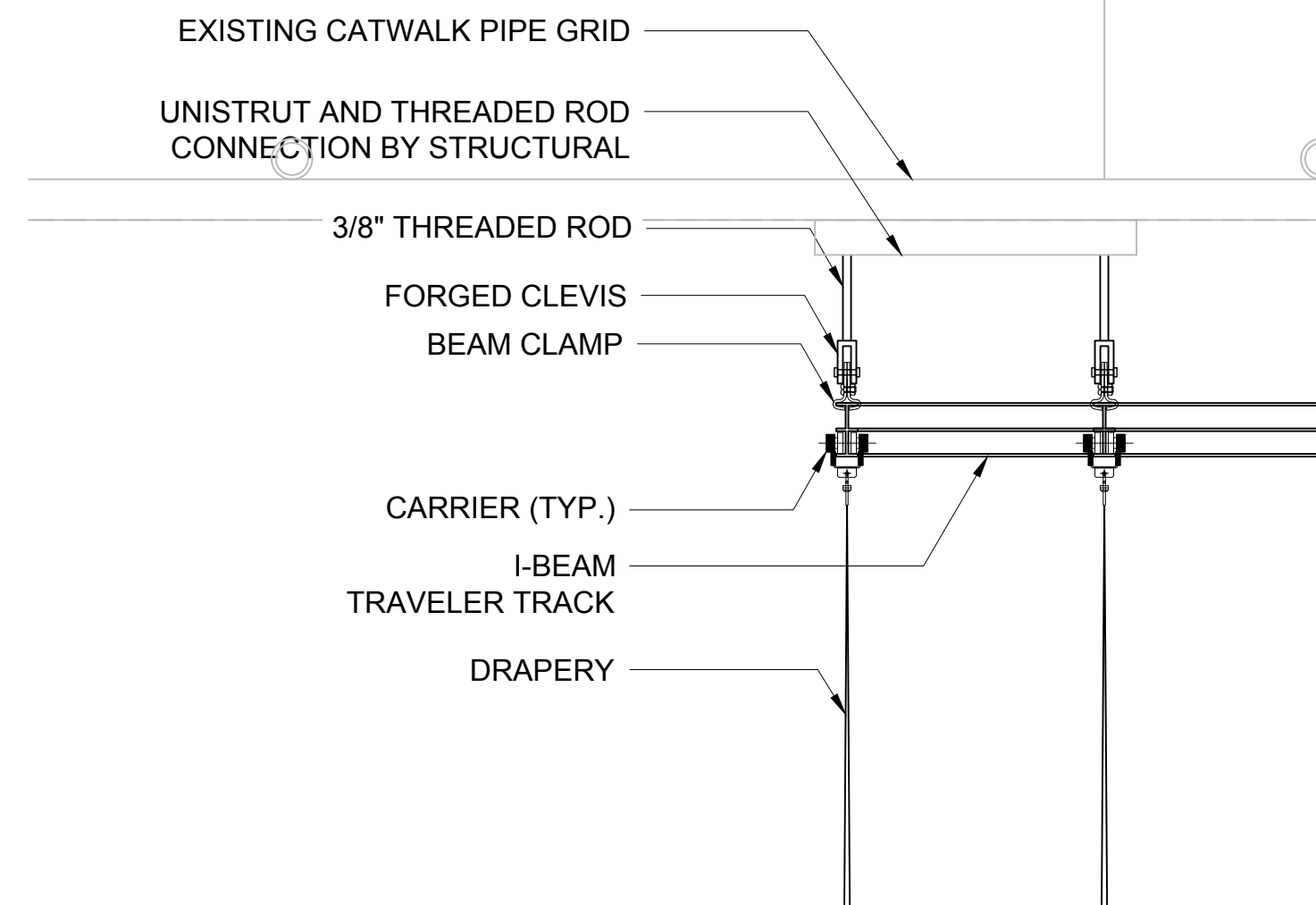

**[ 2 ]** **WALK ALONG TRAVELER TRACK HANGER DETAIL**  
1 1/2"=1'-0"

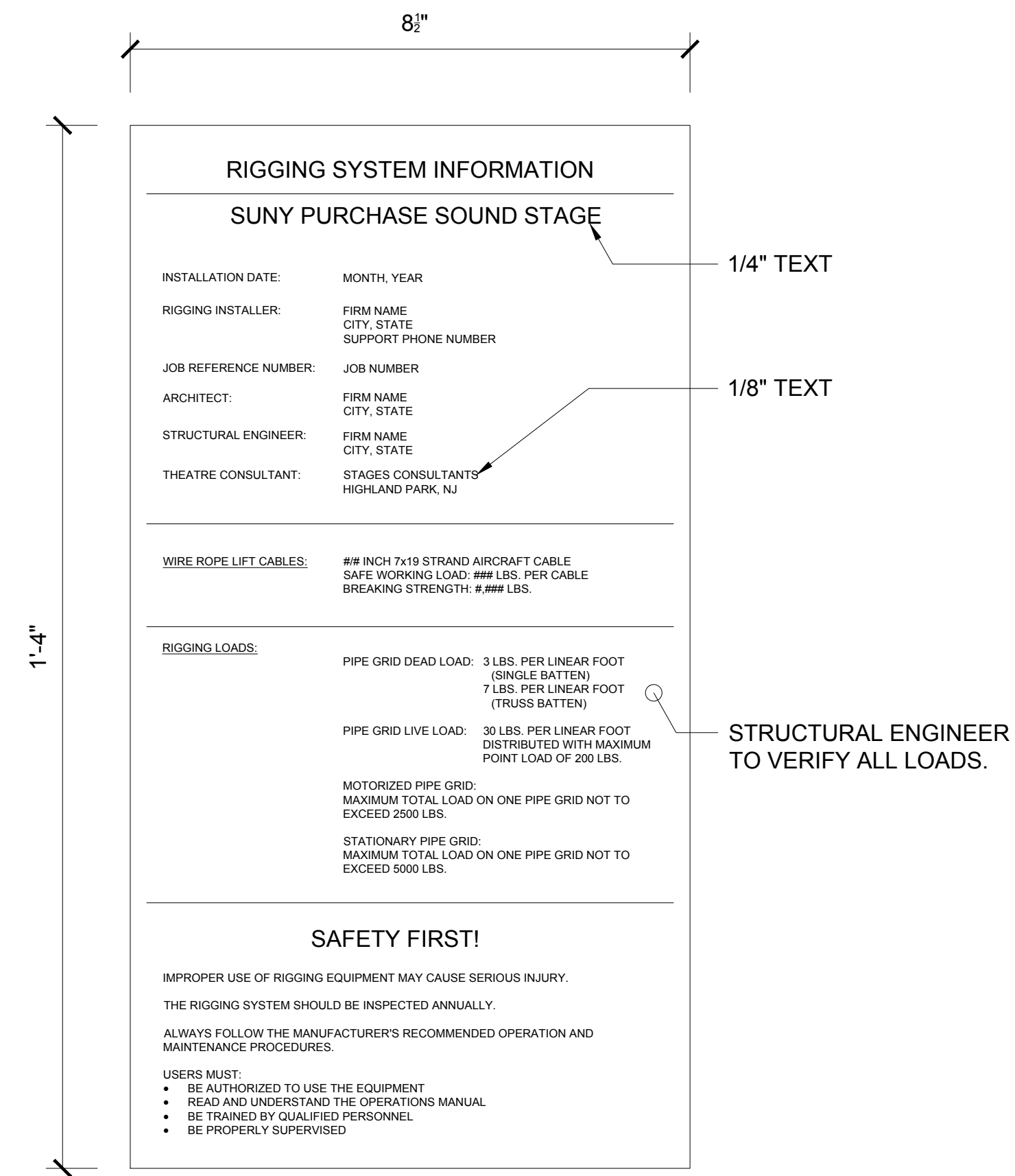

**[ 3 ]** **RIGGING SIGNAGE**  
N.T.S.

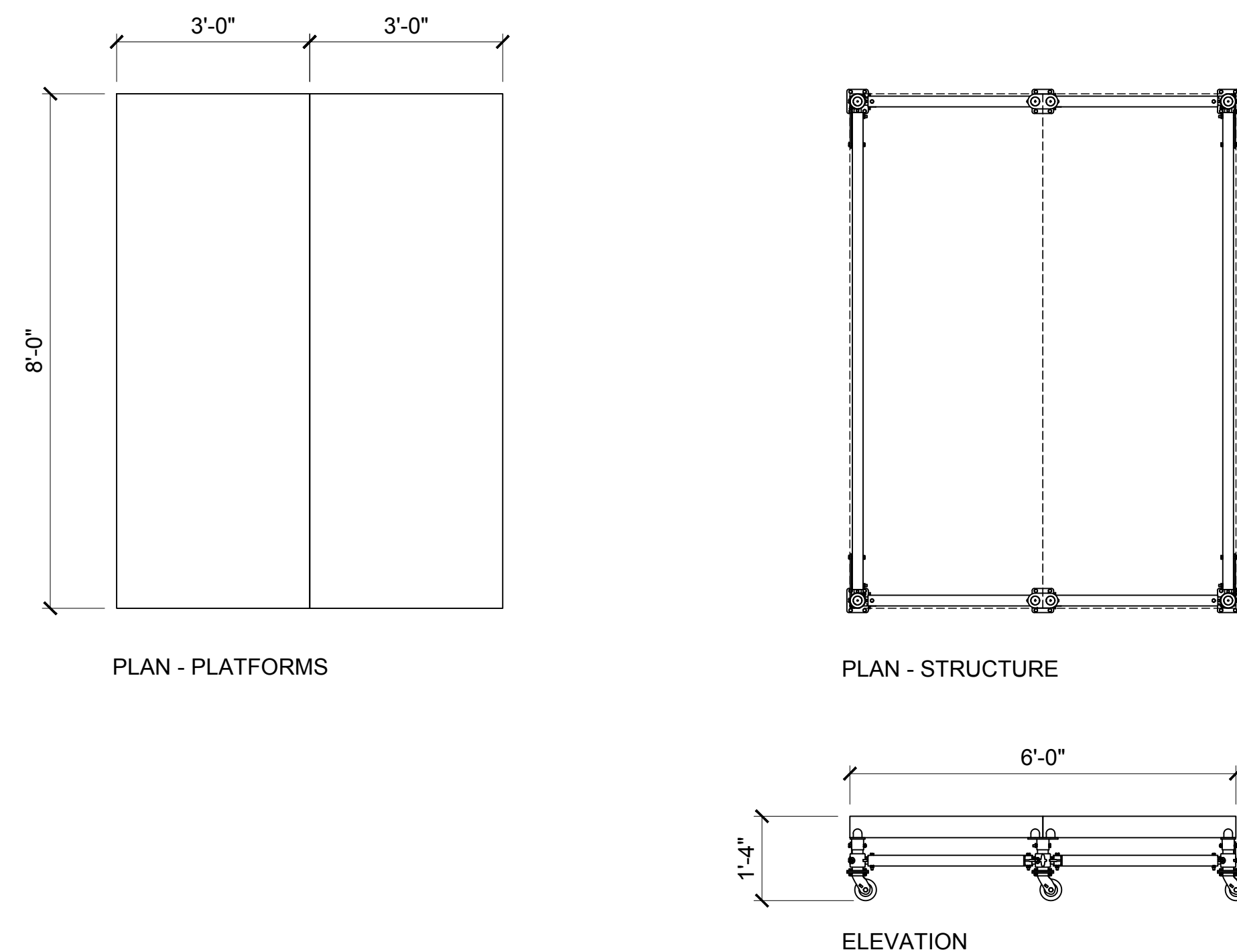

NOTES:  
1. PROVIDE CHAIR STOPS FOR ALL SIDES.  
2. PROVIDE LOCKABLE SWIVEL CASTERS.

**[ 4 ]** **MOBILE CONTROL BOOTH**  
1/2"=1'-0"

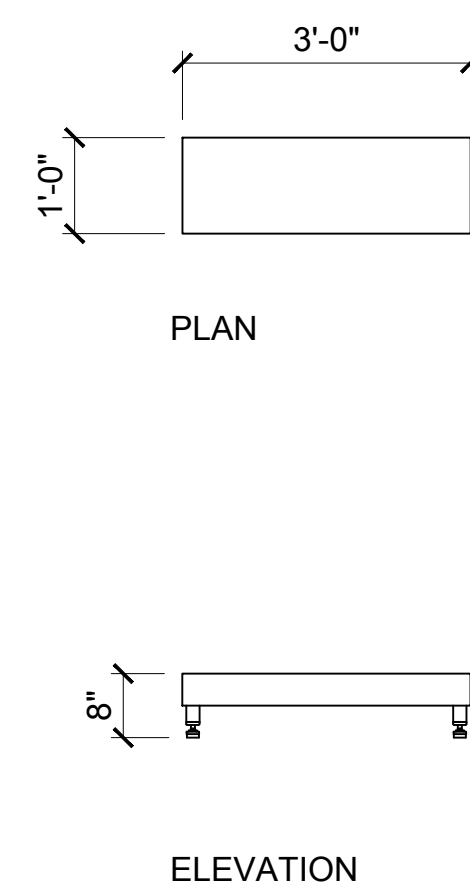

NOTES:  
1. PROVIDE ONE STEP UNIT.  
2. PROVIDE FIXED HEIGHT LEGS FOR STEP HEIGHT INDICATED, TOTAL OF FOUR (4) LEGS.

**[ 5 ]** **STEP UNIT**  
1/2"=1'-0"

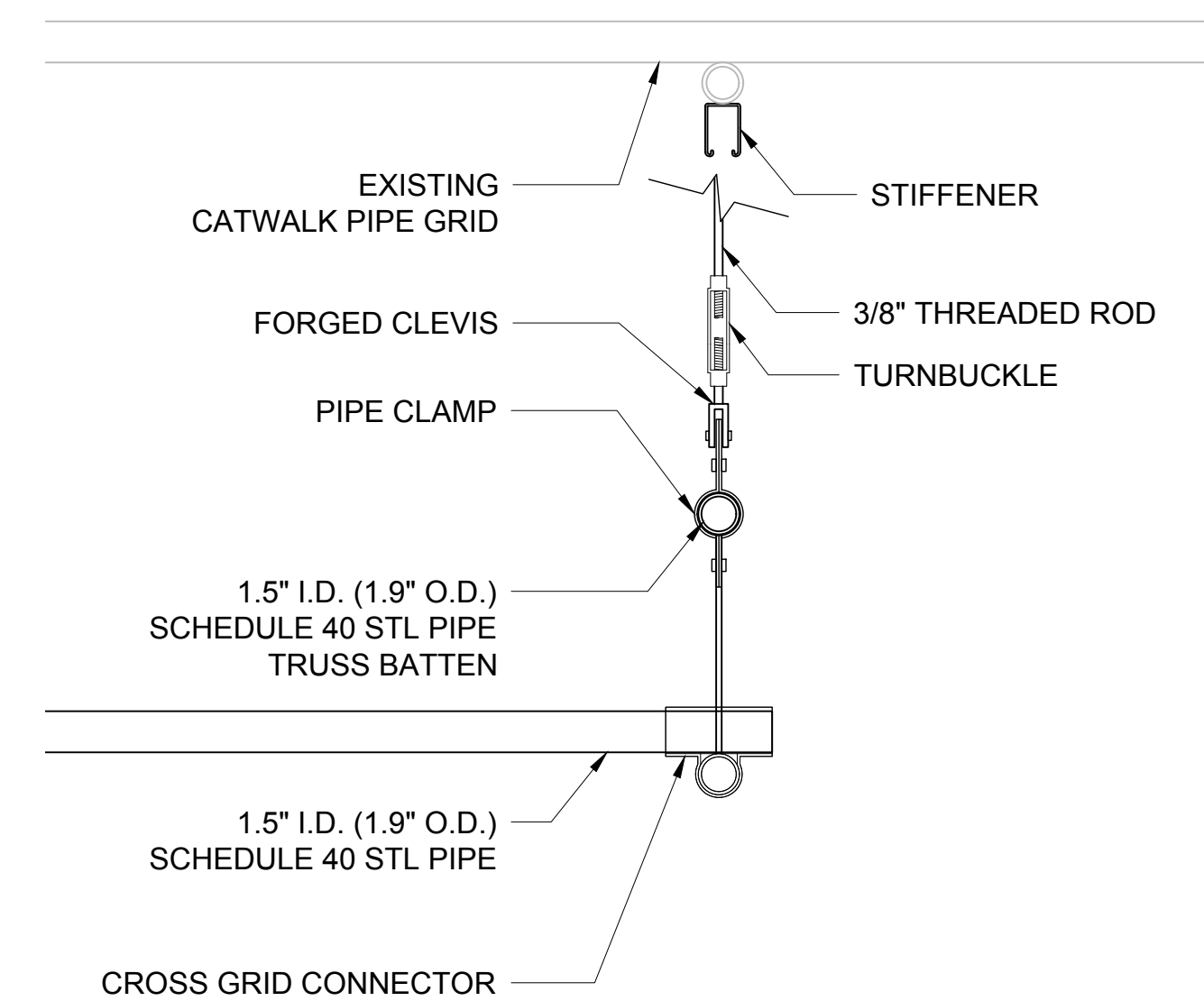

**[ 6 ]** **STATIONARY PIPE GRID HANGER**  
1 1/2"=1'-0"

FOR COORDINATION ONLY.  
PROCURED UNDER  
SEPARATE CONTRACT.

**PURCHASE COLLEGE**  
STATE UNIVERSITY OF NEW YORK  
735 ANDERSON HILL RD  
PURCHASE, NY 10577-1400

ARCHITECT  
**dimovskiarchitecture**  
59 Kensico Road, Thomwood, NY 10594  
(914) 747-3500 | (914) 747-3588 fax  
www.dimovskiarchitecture.com

MEP ENGINEER  
**Collado ENGINEERING**  
2 HOLLAND AVENUE  
WHITE PLAINS NY 10603  
(914) 332-7658

STRUCTURAL ENGINEER  
**SZEWCAK ASSOCIATES**  
CONSULTING ENGINEERS  
AVON PARK NORTH  
200 FERRIS DRIVE  
AVON, CT 06001  
TEL: 860-677-6370  
860-677-6369

STAGE CONSULTANT  
**stages**  
300 Raritan Ave, 2nd Flr Highland Park, NJ 08904  
732.333.8003  
stagesconsultants.com

NO.	REVISION/ISSUE	DATE
2.	ISSUE FOR BID	06/18/2018
1.	ISSUE FOR BUDGETING	06/04/2018

SEAL

PROJECT  
**INTERIOR RENOVATION MUSIC SOUND STAGE**

DATE: 06/18/2018  
PROJECT NO: DA 1845 / SU-062518  
DRAWN BY: SEM  
CHECKED BY: AS  
SCALE: AS NOTED

DRAWING TITLE  
**THEATRE RIGGING DETAILS**

SHEET NO.  
TR1.30

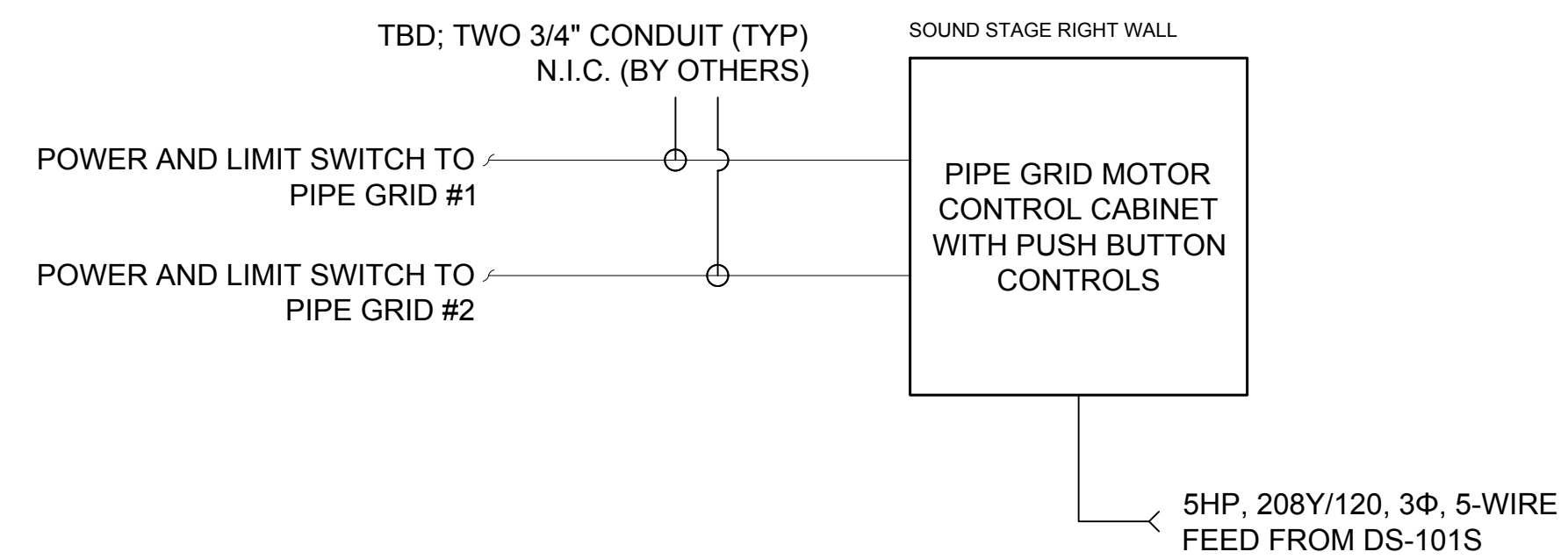

**[ 1 ]** LINE SHAFT HOIST FUNCTIONAL DIAGRAM  
N.T.S.

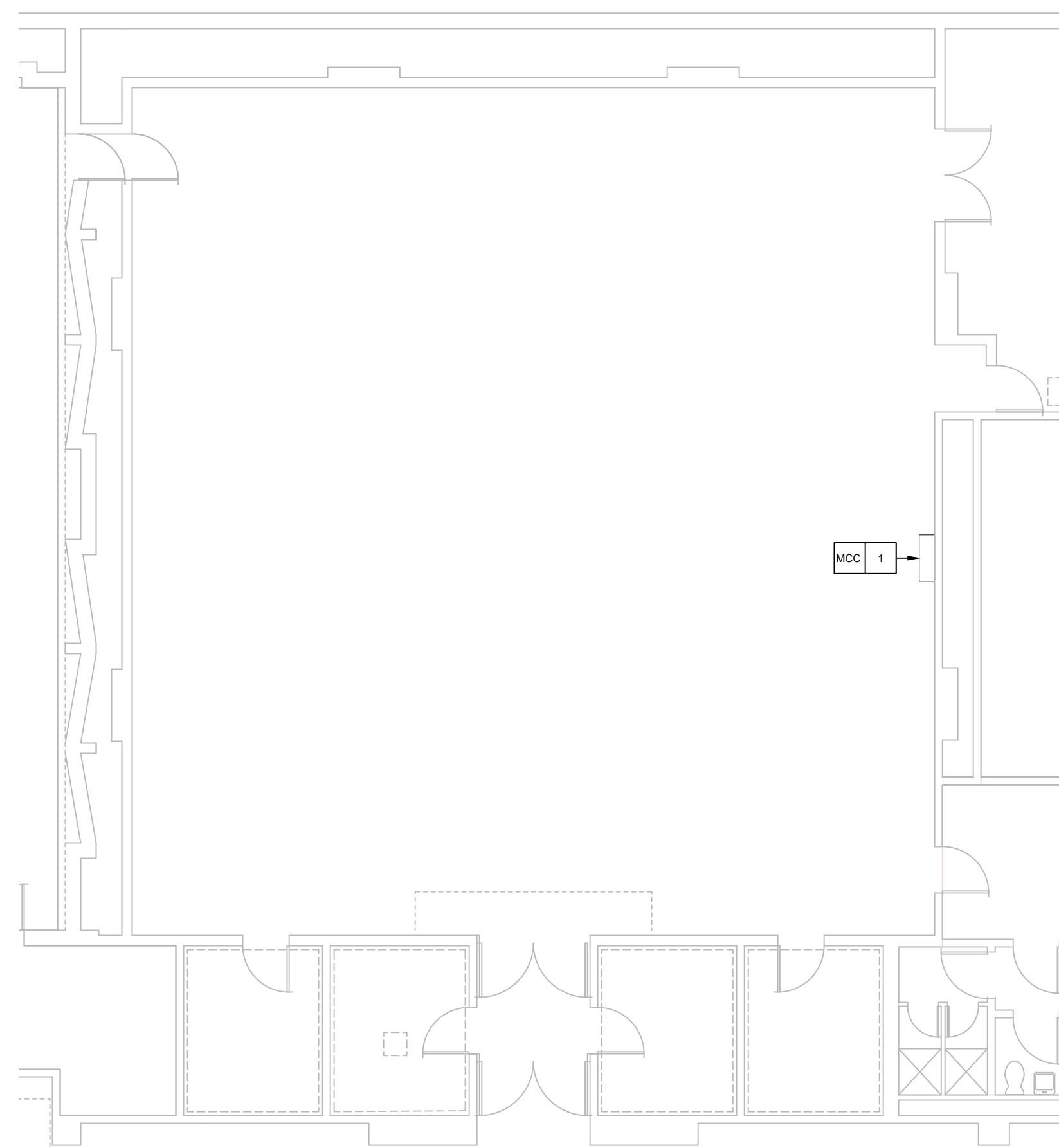

**[ 2 ]** STAGE LEVEL DEVICE PLAN  
1/8"=1'-0"

NOTES:

- THIS DIAGRAM SHOWS THE LAYOUT AND INTERCONNECTION OF THE COMPONENTS IN THE RIGGING ELECTRICAL SYSTEMS TO CONVEY DESIGN INTENT ONLY. FINAL WIRE QUANTITIES, TYPES, AND TOPOLOGY SHALL BE DETERMINED BY THE RIGGING MANUFACTURER.

**PURCHASE COLLEGE**

STATE UNIVERSITY OF NEW YORK

735 ANDERSON HILL RD  
PURCHASE, NY 10577-1400

ARCHITECT

**dimovskiar** architecture P.L.L.C.  
59 Kensico Road, Thornwood, NY 10594  
(914) 747-3500 | (914) 747-3588 fax  
www.dimovskiararchitecture.com

MEP ENGINEER

**Collado**  
ENGINEERING  
2 HOLLAND AVENUE  
WHITE PLAINS NY 10603  
(914) 332-7658

STRUCTURAL ENGINEER

**SZEWCAZ ASSOCIATES**  
CONSULTING ENGINEERS  
AVON PARK NORTH  
200 FERRIS DRIVE  
AVON, CT 06001  
TEL: 860.677.4370  
860.677.4380

STAGE CONSULTANT

**stages**

300 Raritan Ave, 2nd Flr Highland Park, NJ 08904 732.333.8003  
stagesconsultants.com

NO.	REVISION/ISSUE	DATE
2.	ISSUE FOR BID	06/18/2018
1.	ISSUE FOR BUDGETING	06/04/2018

SEAL

PROJECT  
**INTERIOR RENOVATION MUSIC SOUND STAGE**

DATE: 06/18/2018  
PROJECT NO: DA 1845 / SU-062518  
DRAWN BY: SEM  
CHECKED BY: AS  
SCALE: AS NOTED

DRAWING TITLE  
**THEATRE RIGGING ELECTRICAL DETAILS**

SHEET NO.  
TR1.40

FOR COORDINATION ONLY.  
PROCURED UNDER  
SEPARATE CONTRACT.



## RIGGING SYSTEMS AND DRAPERIES

## PART 1 – GENERAL

## 1.1 GENERAL CONDITIONS

- A. THE GENERAL CONDITIONS OF THE CONTRACT DOCUMENTS SHALL APPLY TO THE WORK IN THIS SECTION.

## 1.2 WORK INCLUDED

- A. THE WORK OF THIS SECTION INCLUDES ALL LABOR, MATERIALS, EQUIPMENT AND SERVICES NECESSARY TO COMPLETE THE STAGE RIGGING AND DRAPERIES INSTALLATION, AS SHOWN ON THE DRAWINGS AND SPECIFIED HEREIN, INCLUDING, BUT NOT LIMITED TO, THE FOLLOWING:
- MOTORIZED PIPE GRIDS
  - ADDITIONAL SUPPORT STRUCTURES AS REQUIRED TO MEET THE INTENT OF THE CONTRACT DOCUMENTS
  - TRACKED, WALKALONG STUDIO CURTAINS
  - CONTROL DEVICES FOR MOTORIZED RIGGING.
  - STATIONARY PIPE GRID (ALTERNATE #1)

## 1.3 RELATED WORK

- A. RELATED WORK WHICH IS NOT PART OF THE WORK IN THIS SECTION INCLUDES, BUT IS NOT LIMITED TO, THE FOLLOWING:

- SUPPORT STEEL.
- FINISHES
- POWER FEEDS AND ELECTRICAL WORK FOR MOTORIZED RIGGING, INCLUDING CONDUIT AND WIRE BETWEEN CONTROL COMPONENTS, AND TERMINATIONS.
- STAGE LIGHTING SYSTEM, INCLUDING JUNCTION BOXES AND MULTICONDUCTOR CABLES.
- MECHANICAL SYSTEM.
- FIRE PROTECTION SYSTEM.

## 1.4 DEFINITIONS

- A. FURNISH - SUPPLY EQUIPMENT TO THE PROJECT FOR USE OR INSTALLATION BY OTHERS.  
 B. INSTALL - INSTALL EQUIPMENT PROVIDED TO THE PROJECT BY OTHERS.  
 C. PROVIDE - SUPPLY AND INSTALL EQUIPMENT.

## 1.5 QUALITY ASSURANCE

- A. ALL EQUIPMENT SHALL BE MANUFACTURED AND INSTALLED IN ACCORDANCE WITH THE APPLICABLE STANDARDS OF THE FOLLOWING ORGANIZATIONS:
- AMERICAN IRON AND STEEL INSTITUTE (AISI).
  - AMERICAN NATIONAL STANDARDS INSTITUTE (ANSI).
  - AMERICAN SOCIETY OF MECHANICAL ENGINEERS (ASME).
  - AMERICAN SOCIETY FOR TESTING AND MATERIALS (ASTM).
  - AMERICAN WELDING SOCIETY (AWS).
  - ENTERTAINMENT SERVICES AND TECHNOLOGY ASSOCIATION (ESTA).
  - INDUSTRIAL FASTENERS INSTITUTE (IFI).
  - INTERNATIONAL ORGANIZATION FOR STANDARDIZATION (ISO).
  - NATIONAL ASSOCIATION OF CHAIN MANUFACTURERS (NACM).
  - NATIONAL FIRE PROTECTION INSTITUTE (NFPA).
  - SOCIETY OF AUTOMOTIVE ENGINEERS (SAE).
  - AMERICAN GEAR MANUFACTURERS ASSOCIATION (AGMA).
  - NATIONAL ELECTRICAL CODE (NEC).
  - NATIONAL ELECTRICAL MANUFACTURERS ASSOCIATION (NEMA).
- B. MINIMUM DESIGN FACTOR FOR LIFTED LOADS: 8:1. DESIGN FACTOR SHALL INCLUDE THE EFFECTS OF STATIC LOADS, DYNAMIC IMPACT LOADS AND REDUCTIONS FOR END TERMINATIONS AND BENDING RATIOS.
- C. MINIMUM DESIGN FACTOR FOR STATIC LOADS: 6:1. DESIGN FACTOR SHALL INCLUDE THE EFFECTS OF STATIC LOADS AND REDUCTIONS FOR END TERMINATIONS AND BENDING RATIOS.
- D. MAXIMUM FLEET ANGLE: 1-1/2 DEGREES.
- E. CABLE BENDING RATIO FOR MANUALLY OPERATED SYSTEMS SHALL BE AT LEAST 30 TIMES THE DIAMETER OF THE CABLE. MOTORIZED SYSTEMS SHALL COMPLY WITH THE WIRE ROPE MANUFACTURER'S MINIMUM RECOMMENDED BENDING RATIO.
- F. WIRE ROPE CLIPS SHALL BE DROP-FORGED.
- G. FASTENERS TYPICALLY SHALL HAVE A MINIMUM SAE J429 GRADE 5 OR ISO R888 CLASS 8.8 RATING. BOLTS IN TENSION SHALL HAVE NUTS OF EQUIVALENT RATING. FASTENERS SHALL BE SELF-LOCKING OR SECURED BY ALTERNATE MEANS TO PREVENT LOOSENING.
- H. SHACKLES AND TURNBUCKLE JAWS SHALL HAVE SCREW PINS, MOUSED WITH PLASTIC TIE-WRAP AFTER INSTALLATION.
- I. HELICALLY GROOVED DRUMS SHALL ACCEPT THE WIRE ROPE IN A SINGLE LAYER, PLUS 3 DEAD WRAPS. DRUM CONSTRUCTION SHALL BE ALL-WELDED. LIFTING LINES SHALL ENTER THE DRUM THROUGH THE TUBING WALL AT A 45 DEGREE ANGLE, AND SHALL BE RETAINED BY A COPPER NICOPRESS STOP SLEEVE.
- J. OVERSPEED BRAKES SHALL REQUIRE NEITHER ELECTRICITY NOR EXTERNAL PRESSURE FOR OPERATION. THE BRAKE SHALL BE FACTORY SET TO AUTOMATICALLY APPLY ITSELF AT 125 PERCENT OF THE MAXIMUM RATED WINCH SPEED LOCATE THE BRAKE EITHER ON THE LOW SPEED OUTPUT SHAFT OF THE REDUCER, OR DIRECTLY TO THE LIFTING LINE DRUM.
- K. ROTARY LIMIT CHAIN SPROCKETS SHALL BE PINNED TO PREVENT SLIPPING AND SIZED FOR MAXIMUM USABLE ROTATION OF THE SWITCH CAMS.
- L. LIMIT SWITCH CHAINS AND ENCODER BELTS LOCATED IN TRAFFICKED AREAS SHALL BE FULLY GUARDED.

- M. GEARMOTOR SERVICE FACTORS AND LOAD CLASSIFICATIONS SHALL CONFORM TO AGMA RECOMMENDATIONS. THE MINIMUM SERVICE FACTOR SHALL BE 1.0 FOR CONTINUOUS OPERATION AND THE MINIMUM GEARING SERVICE FACTOR SHALL BE 1.0 WITH A MINIMUM MECHANICAL SERVICE FACTOR OF 1.3.
- N. FIXED SPEED MOTORS SHALL HAVE HIGH INERTIA FANS OR ELECTRONIC "SOFT" STOPPING AND STARTING CHARACTERISTICS AS DICTATED BY THE LOAD CAPACITY AND SPEED OF THE WINCH.
- O. SHAFTING SHALL BE KEYPED AND DESIGNED TO MEET ANSI STANDARDS IN ORDER TO PROPERLY TRANSMIT APPLIED LOADS AND TORQUES WITH ALLOWANCE FOR IMPACT.
- P. CHAIN TRANSMISSION SHALL BE MADE WITH ROLLER CHAIN SELECTED TO MEET ANSI STANDARDS AND SAFELY TRANSMIT THE FULL LOAD, INCLUDING IMPACT, APPLIED BY THE MOTOR AND THE UNBALANCED SET. THE STRENGTH OF THE CHAIN CONNECTORS SHALL BE EQUAL TO THE STRENGTH OF THE CHAIN. PROVIDE A MEANS OF LUBRICATING AND TIGHTENING THE CHAINS.
- Q. THIS SPECIFICATION SETS FORTH MINIMUM SAFETY STANDARDS, OPERATIONAL CRITERIA, AND MINIMUM STANDARDS FOR QUALITY IN WORKMANSHIP. IT IS THE SOLE RESPONSIBILITY OF THE CONTRACTOR TO DESIGN, ENGINEER, FURNISH AND INSTALL A SAFE, FULLY FUNCTIONAL SYSTEM IN COMPLIANCE WITH THE DESIGN INTENT OF THE CONTRACT DOCUMENTS.

## 1.6 SUBMITTALS

- A. SUBMIT THE FOLLOWING WITH THE BID:
- BILL OF MATERIALS, WITH PARTS IDENTIFIED BY COMMON INDUSTRY STANDARD NUMBERS AND/OR DESCRIPTIONS.
  - SPECIFIED MANUFACTURER'S CATALOG CUT SHEETS OF ALL PRODUCTS CALLED OUT IN THE BILL OF MATERIALS.
  - STATEMENT THAT THE MANUFACTURER AGREES TO THE WARRANTY PROVISIONS.
  - PROJECTED TIMETABLE LISTING THE TIME IN WEEKS FOR EACH OF THE FOLLOWING ACTIVITIES:
    - SHOP DRAWING PREPARATION
    - FABRICATION
    - SHIPPING TO SITE
    - SYSTEM COMMISSIONING
    - AS BUILT DRAWING PREPARATION
- B. SHOP DRAWINGS
- SUBMIT SHOP DRAWINGS FOR REVIEW. DRAWING SHEET SIZE SHALL BE UNIFORM. SUBMITTALS OF MORE THAN 5 DRAWINGS SHALL BE BOUND.
  - SHOP DRAWINGS SHALL BE STAMPED BY A STRUCTURAL ENGINEER LICENSED IN THE STATE OF NEW YORK.
  - SHOP DRAWINGS SHALL INCLUDE:
    - TITLE SHEET LISTING ALL SHEETS IN THE SUBMITTAL.
    - SCALE PLANS AND ELEVATIONS.
    - ALL INFORMATION NECESSARY TO EXPLAIN FULLY THE DESIGN FEATURES, APPEARANCE, FUNCTION, FABRICATION, INSTALLATION, AND USE OF SYSTEM COMPONENTS IN ALL PHASES OF OPERATION.
    - COUNTRY OF ORIGIN FOR EQUIPMENT
  - FABRICATION SHALL NOT COMMENCE UNTIL THE THEATRE CONSULTANT AND THE ARCHITECT DETERMINE THAT THE SHOP DRAWINGS ARE IN COMPLIANCE WITH THE DESIGN INTENT OF THE CONTRACT DOCUMENTS.
  - SHOP DRAWINGS SHALL BE REVISED AND RESUBMITTED AS REQUIRED.

## C. MANUALS

- PROVIDE AN OPERATIONS AND MAINTENANCE MANUAL TO THE OWNER AT TIME OF OWNER TRAINING. THE MANUAL SHALL INCLUDE:
    - CONTRACTOR CONTACT INFORMATION
    - MANUFACTURER CONTACT INFORMATION
    - SYSTEM DESCRIPTION
    - OPERATION INSTRUCTIONS, INCLUDING SAFETY MEASURES
    - MAINTENANCE INSTRUCTIONS, INCLUDING RECOMMENDED PROCEDURES AND SCHEDULES FOR INSPECTING SYSTEM COMPONENTS
    - EQUIPMENT DESIGN PARAMETERS INCLUDING SAFE WORKING LOADS AND DUTY CYCLES.
    - PARTS AND SUBASSEMBLY LISTS
    - REPLACEMENT PARTS SOURCE INFORMATION
    - CATALOG CUTS FOR ALL PURCHASED EQUIPMENT
  - PROVIDE THE ABOVE DOCUMENTS IN PRINTABLE ELECTRONIC FORMAT, SUCH AS PDF OR OTHER UNIVERSAL FORMAT FILES, ON USB STORAGE DRIVES.
- D. AS-BUILT DRAWINGS
- WITHIN ONE MONTH OF SYSTEM ACCEPTANCE, PROVIDE COMPLETE AS-BUILT DRAWINGS. THE AS-BUILT DRAWINGS SHALL INCLUDE:
    - FINAL SHOP DRAWINGS.
    - FINAL BILL OF MATERIALS.
  - PROVIDE THE AS-BUILT DRAWINGS IN PRINTABLE ELECTRONIC FORMAT, SUCH AS PDF OR OTHER UNIVERSAL FORMAT FILES, ON USB STORAGE DRIVES.

## 1.7 WARRANTY

- A. THE MANUFACTURER SHALL WARRANT THE EQUIPMENT AS FOLLOWS:
- PART ONE - ACCORDING TO THE GUARANTEE PROVISIONS IN THE GENERAL CONDITIONS

## PART 2 – EQUIPMENT

## 2.1 ACCEPTABLE CONTRACTORS

- A. THE EQUIPMENT SHALL BE FURNISHED, INSTALLED, AND PROVIDED BY ONLY ONE OF THE FOLLOWING:
- I. WEISS THEATRICAL SOLUTIONS  
815 FAIRVIEW AVENUE #10  
FAIRVIEW, NJ 07022
  - J. R. CLANCY/WENGER  
7041 INTERSTATE ISLAND ROAD  
SYRACUSE, NY 13209  
315.451.3440
  - POOK DIEMONT AND OHL, INC./ TEXAS SCENIC COMPANY  
701 EAST 132ND STREET  
BRONX, NEW YORK, 10454  
718.402.2677
  - PROTECH THEATRICAL SERVICES  
3431 NORTH BRUCE STREET  
NORTH LAS VEGAS, NV 89030  
702.639.0290
  - SAPSIS RIGGING  
233 NORTH LANSDOWNE AVENUE  
LANSDOWNE, PA 19050  
215.228.0888
  - STARLITE  
9 WHITTENDALE DRIVE  
MOORESTOWN, NJ 08057  
856.780.8000
- B. ADDITIONAL COMPANIES WISHING TO BID SHALL SUBMIT THE FOLLOWING A MINIMUM OF 5 BUSINESS DAYS BEFORE SUBMISSION OF BIDS, FOR REVIEW AND APPROVAL BY THE THEATRE CONSULTANT:
- FIRM HISTORY.
  - A LIST OF COMPLETED INSTALLATIONS WHICH ARE COMPARABLE IN SCOPE TO THE JOB DESCRIBED HERE.
  - A MINIMUM OF 5 REPRESENTATIVE SHOP DRAWING SHEETS.
  - IF REQUESTED, A CURRENT CERTIFIED FINANCIAL STATEMENT SHOWING SUFFICIENT FINANCIAL BASE FOR THE SIZE OF JOB DESCRIBED HERE.

## 2.2 FINISHES

- A. METAL PARTS SHALL BE FREE FROM RUST, SCALE, DIRT, AND WELDING SPATTER. ALL WELDMENTS OR OTHER METAL COMPONENTS SHALL RECEIVE A COAT OF CORROSION RESISTANT PRIMER PRIOR TO FINISH COATING AND COMPONENT ASSEMBLY.
- B. FINISH COAT SHALL BE FLAT ALKYD ENAMEL. COLOR SHALL BE BLACK, EXCEPT WHERE NOTED OTHERWISE IN THE CONTRACT DOCUMENTS.
- 2.3 LIFTING LINES
- A. LIFTING LINES SHALL BE OF SUFFICIENT DIAMETER AND APPROPRIATE CLASSIFICATION TO SUIT THE SYSTEM OPERATIONAL REQUIREMENTS. MINIMUM STANDARD FOR OVERHEAD LIFTING: 7X19 IWRC
- B. DO NOT USE ANY DAMAGED OR PERMANENTLY DEFORMED WIRE ROPE.
- C. USE CONTINUOUS LINES FROM THE SAME SPOOL, FREE OF KNOTS, SPLICES OR INTERMEDIATE FASTENERS UNLESS SPECIFICALLY CALLED FOR ELSEWHERE IN THE CONTRACT DOCUMENTS.

## 2.4 PIPE GRID TERMINATIONS

- A. LIFTING LINE TERMINATIONS AT THE MOTORIZED PIPE GRIDS SHALL CONSIST OF A THIMBLE, A COPPER NICOPRESS FITTING, A JAW/JAW TURNBUCKLE, AND A PIPE CLAMP. MOUSE TURNBUCKLES WITH PLASTIC TIE WRAP. WIRE MOUSING IS NOT ACCEPTABLE.
- B. SECURE THE LOOSE ENDS OF THE WIRE ROPE TO THE STANDING PORTION OF THE LINES WITH PLASTIC TIE WRAP.
- C. SECURE THE LOOSE ENDS OF THE WIRE ROPE TO THE STANDING PORTION OF THE LINES WITH PLASTIC TIE WRAP.
- D. PROVIDE PIPE GRID HANGERS FOR STATIONARY PIPE GRID AS SHOWN ON THE DRAWINGS. DESIGN THE HANGER ASSEMBLIES FOR THE DEAD LOAD OF THE PIPE GRID, PLUS A MINIMUM LIVE LOAD OF 30 LBS. PER LINEAR FOOT TO MAXIMUM ANTICIPATED TOTAL LIVE LOADS AS NOTED:
- STATIONARY PIPE GRID MAXIMUM ANTICIPATED LIVE LOAD IS 5000 POUNDS.

## 2.5 PIPE GRID

- A. THE PIPE GRID SHALL CONSIST OF 1-1/2-INCH NOMINAL DIAMETER STANDARD WEIGHT (SCHEDULE 40) PIPE CONNECTED WITH CLAMPS.
- B. CLAMPS SHALL BE JR CLANCY "CROSS GRID CONNECTORS", OR APPROVED SUBSTITUTE. PROVIDE A CLAMP AT EVERY PIPE INTERSECTION.
- C. PIPE SPLICES SHALL BE MADE WITH AN 18-INCH-LONG, 1-9/16-INCH DIAMETER DOM TUBE WITH A MINIMUM WALL THICKNESS OF 3/16-INCH. WELD ONE END OF THE SPLICE TUBE. FASTEN THE OTHER END WITH TWO 3/8-INCH BOLTS.
- D. PAINT THE PIPE GRID AND HANGER ASSEMBLIES BLACK.

2. PART TWO - ADDITIONALLY, FOR TWO YEARS FROM ACCEPTANCE OF THE SYSTEMS, PROVIDE SERVICES DETAILED BELOW:

- PROVIDE FOR THE OWNER'S OPERATING STAFF A TECHNICAL AND OPERATIONAL ASSISTANCE HOTLINE ADVICE SERVICE AT NO ADDITIONAL COST FOR THE DURATION OF THE WARRANTY PERIOD. SUCH ADVICE TO BE AVAILABLE DURING NORMAL WORKING HOURS AND ON EVENINGS AND WEEKENDS.
- PROVIDE ALL REQUIRED MAINTENANCE OR REPLACEMENT WITHIN 30 DAYS OF NOTIFICATION BY THE OWNER, WITH THE FOLLOWING EXCEPTION: ALL REQUIRED MAINTENANCE OR REPLACEMENT WHICH AFFECTS THE SAFE OPERATION OF THE INSTALLATION SHALL BE ACCOMPLISHED WITHIN 3 DAYS.

## 2.6 SHEAVES

- A. SHEAVES FOR MANUAL SETS SHALL BE MADE FROM HIGH STRENGTH NYLON RESIN OR REINFORCED POLYMER COMPOSITE.
- B. SHEAVE GROOVES SHALL CONFORM TO CABLE AND ROPE MANUFACTURERS' STANDARDS FOR GROOVE SHAPE AND TOLERANCE.
- C. SHEAVES SHALL HAVE PRECISION BALL BEARINGS. BEARINGS SHALL BE RATED FOR THE MAXIMUM STATIC AND DYNAMIC LOADS AT 300 FEET PER MINUTE MAXIMUM RPM, PLUS MANUFACTURER'S RECOMMENDED SAFETY FACTOR. MINIMUM LIFESPAN RATING: 2000 HOURS.
- D. SHAFTS SHALL BE MADE OF MACHINED STEEL.
- E. SHEAVE HUBS SHALL BE SIZED TO PROVIDE ADEQUATE LOAD SUPPORT FOR THE BEARING ASSEMBLY. HUB BORES SHALL CONFORM TO THE TOLERANCES OF THE BEARING MANUFACTURER.
- F. SHEAVES SHALL ROTATE PLUMB AND TRUE WITHOUT TOUCHING THE SIDE PLATES.

## 2.7 LOFT BLOCKS

- A. LOFT BLOCKS SHALL BE DESIGNED AND FABRICATED TO SUPPORT A 500-POUND MINIMUM MANUFACTURER'S RECOMMENDED WORKING LOAD.
- B. LOFT BLOCK SHEAVES SHALL BE 8 INCHES IN DIAMETER.
- C. SHEAVES SHALL HAVE 5/8-INCH MINIMUM DIAMETER SHAFTS.
- D. SIDE PLATE THICKNESS SHALL BE 12-GAUGE MINIMUM. PROVIDE PIPE SPACERS TO STIFFEN THE SIDE PLATES AND PREVENT THE WIRE ROPE FROM LEAVING THE GROOVES.
- E. BASE ANGLES SHALL BE 1-1/2 X 1-1/2-INCH MINIMUM.
- F. EACH LOFT BLOCK SHALL HAVE A SINGLE-LINE SHEAVE.
- G. LOFT BLOCKS SHALL BE LABELED WITH THE FOLLOWING INFORMATION:
- MANUFACTURER CONTACT INFORMATION
  - RECOMMENDED WEIGHT LIMIT CAPACITY.

## 2.8 PIPE GRID HOIST

- A. LINE SHAFT HOISTS SHALL HAVE THE FOLLOWING FEATURES:
- CAPACITY: 2500 POUNDS
  - SPEED: 20 FEET PER MINUTE
  - SPRING APPLIED, ELECTRICALLY RELEASED MOTOR BRAKE RATED FOR 125% OF THE MOTOR FULL LOAD TORQUE
  - SECONDARY MECHANICAL BRAKE (LOAD OR OVERSPEED)
  - ROTARY LIMIT SWITCH FOR HIGH AND LOW TRAVEL AND OVERTRAVEL TRIMS.
- B. DRUMS SHALL BE 8-INCH DIAMETER, HELICALLY GROOVED FOR WIRE ROPE. DRUMS SHALL ACCEPT THE WIRE ROPE IN A SINGLE LAYER, PLUS THREE DEAD WRAPS.
- C. MAINTENANCE AND SETUP CONTROLS SHALL BE PROVIDED.
- 2.9 CABLE MANAGEMENT
- A. PROVIDE PLASTIC OR WOODEN TUBS TO COLLECT AND DEPLOY STAGE LIGHTING POWER AND CONTROL CABLE AS THE GRIDS RAISE AND LOWER. PAINT THE ASSEMBLY BLACK.
- 2.10 MOTORIZED RIGGING CONTROLS
- A. THE CONTROLS FOR THE RIGGING SYSTEM SHALL BE INTEGRAL TO THE MOTOR CONTROL CABINET AND SHALL INCLUDE THE FOLLOWING FEATURES:
- KEY OPERATED POWER SWITCH.
  - HOLD-TO-OPERATE UP AND DOWN OPERATION PUSHBUTTONS WITH INDICATOR LIGHTS THAT ILLUMINATE WHEN A BUTTON IS PRESSED AND THE MOTOR HAS REACHED ITS CORRESPONDING LIMIT.
  - DEDICATED E-STOP BUTTON

## 2.11 SIGNAGE

- A. PROVIDE "RIGGING INFORMATION" SIGNS, AS ILLUSTRATED IN THE DRAWINGS. WALL MOUNT ADJACENT TO RIGGING CONTROLLER.
- B. PROTECT THE ABOVE SIGNS WITH 1/8-INCH-THICK TRANSPARENT PLASTIC SHEETS SCREWED TO THE WALL.

## 2.12 STAGE DRAPERY SCHEDULE

- A. STUDIO DRAPERY SCHEDULE IS AS FOLLOWS:

DESCRIPTION	QUANTITY	HEIGHT	WIDTH
BLACKOUT	4	22'-0"	30'-0"
CYC	1	22'-0"	50'-0"
GREEN SCREEN	1	22'-0"	50'-0"

## 2.13 FABRICS

- A. BLACKOUT DRAPES: 24 OUNCE, 100% TREVIRA CS POLYESTER, INHERENTLY FLAME RETARDANT VELOUR, KM FABRICS' "CHARISMA", OR APPROVED EQUAL. COLOR: BLACK.
- B. MUSLIN CYCLORAMA: 100 PERCENT COTTON, .7 OUNCE PER SQUARE FOOT, SEAMLESS FABRIC. COLOR: BLEACHED WHITE.
- C. GREEN SCREEN: 62" WIDE, INHERENTLY FLAME RETARDANT, ROSE BRAND POLY PRO, OR APPROVED EQUAL. COLOR: CHROMA KEY GREEN.
- D. FABRICS SHALL BE FLAME TREATED IN A MANNER APPROVED BY THE APPROPRIATE LOCAL AGENCY, WHERE APPLICABLE. A NOTARIZED AFFIDAVIT SHALL ACCOMPANY THE DRAPERIES ATTESTING THAT ALL FABRICS HAVE BEEN FLAME TREATED IN THE APPROVED MANNER.
- E. NO PIECED HORIZONTAL OR SPLIT WIDTHS OF FABRIC SHALL BE INCORPORATED IN ANY PART OF ANY DRAPERY.
- F. FABRICS OF 1 COLOR SHALL BE FROM 1 DYE LOT.
- G. VELOUR NAP SHALL RUN IN A CONSISTENT DIRECTION. NAP SHALL RUN UP FOR BLACK VELOUR MASKING PIECES.

# PURCHASE COLLEGE

STATE UNIVERSITY OF NEW YORK

735 ANDERSON HILL RD  
PURCHASE, NY 10577-1400

## ARCHITECT



## MEP ENGINEER



## STRUCTURAL ENGINEER



## STAGE CONSULTANT

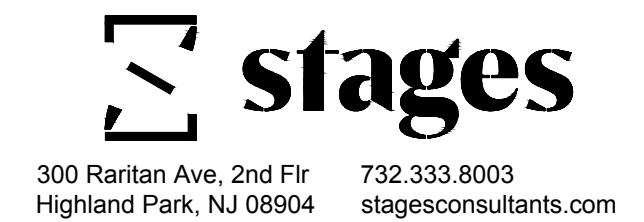

NO.	REVISION/ISSUE	DATE
2.	ISSUE FOR BID	06/18/2018
1.	ISSUE FOR BUDGETING	06/04/2018



PROJECT

## INTERIOR RENOVATION MUSIC SOUND STAGE

DATE:	06/18/2018
PROJECT NO:	DA 1845 / SU-062518
DRAWN BY:	SEM
CHECKED BY:	AS
SCALE:	AS NOTED

DRAWING TITLE

## THEATRE RIGGING SPECIFICATIONS

SHEET NO.	TR2.01
-----------	--------

FOR COORDINATION ONLY.  
PROCURED UNDER  
SEPARATE CONTRACT.



